

# HIGH-EFFICIENCY COMMERCIAL WASHER



## Featuring Mechanical Controls



### CAM2762TQ 27" Two-Speed Washer with Metercase

Machine Accepts the Following Compatible Payment Systems (not included):

- Coin Slide
- Retrofit Coin-Drop
- Retrofit Card Reader
- OPL Push-to-Start Kit (No Coins Needed)
- 3.2 Cu. Ft. Wash Basket, 18 Lbs. UL
- Push-Button Controls
- High-Efficiency, Low-Water Factor
- 3 Cycles: Heavy (Hot/Cold), Permanent Press (Warm/Cold) and Colorfast (Cold/Cold)
- 3 Cycle Indicator Lamps
- Two-Speed Advantage with True Gentle Wash, High Speed Spin Only
- Deep Rinse System, Automatic Temperature Control 115°H/85°W

\* Testing completed 11/12/2001.

\*\* Call 1-800-NO-BELTS for warranty details.

- Porcelain Top and Lid, Rust-Proof Stainless Steel Torx® Control Panel Screws and Stainless Steel Hinges
- Galvanized, Heavy Gauge Cabinet Back, Side and Front Panels, Removable Front Service Panel
- High-Speed Spin – 640 RPM (approximate)
- Motor: 1/2-HP with Built-In Overload Protector: 120 Volt, 60 Hz., A.C. Agitation Speed 180 SPM/High 120 SPM/Low
- Heavy-Duty Motor Coupler Isolator Tested to 20,000 Cycles\*
- Extra-Long Power Cord and Commercial-Grade Color-Coded Water Inlet Hoses with Brass Couplings and EDPM Rubber Drain Hose
- **3 Years Limited Parts Only Warranty\*\***
- **Money Acceptors Sold Separately**

### FOR YOUR CUSTOMERS

- Large Capacity Wash Basket is Ideal for Family-Size Loads
- 3 Cycle Options: Heavy, Permanent Press and Colorfast for a Wide Range of Fabrics

### DIRECT DRIVE SYSTEM

- 27" Heavy-Duty Commercial Washer Features the Reliable Direct-Drive, No-Belt Washing System for Greater Reliability, Reduced Downtime and Increased Profits
- Front and Bottom Serviceable



### TRIPOD SUSPENSION

Sturdy tripod-suspension with active liquid filled balance ring reduces product weight while balancing commercial-size laundry loads.



### SEALED HIDDEN LID SWITCH

To help ensure safe operation, Whirlpool® Commercial Washers feature a lid switch that is truly hidden. Prevents tampering and ensures the washer will not operate when the lid is open.

### Reduce Water Consumption to 23.22 Gallons per Cycle†

†Based on low-water level, 3 lb. load

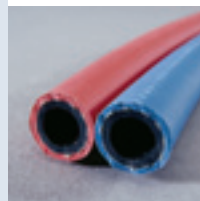

### INDUSTRIAL STRENGTH WATER INLET HOSES

Tested to 1100 PSI.

# HIGH-EFFICIENCY COMMERCIAL WASHER



## Featuring Mechanical Controls

### Whirlpool® On-Premise Non-Metered Commercial Washer Mechanical Controls

WASHER SPECIFICATIONS	
<b>MODEL</b>	<b>CAM2762TQ</b>
<b>GENERAL INFORMATION</b>	
Accepts the following payment systems: Coin Slide, Retrofit Coin-Drop, Retrofit Card Reader and OPL Push-To-Start	High-Efficiency Deep Rinse, Electronic Temperature Control, Super Capacity 3.2 Cu. Ft. Basket, High- and Low-Water Level Settings
Stainless steel look push-button console, hidden lid switch, porcelain finish top and lid, galvanized, extra thick front panel, side and back panels, improved metercase, front panel lock blank factory installed. Commercial-grade, color-coded, water inlet hoses with brass couplings and rubber drain hose included	
<b>BASKET VOLUME</b>	3.2 Cu. Ft. (18 Lbs. UL)
<b>MOTOR</b>	
120-Volt ½-HP Direct Drive with Built-In Overload Protector	Two-Speed Advantage with True Gentle Wash, High-Speed Spin Only
Motor RPM	1725 High, 1140 Low
Spin RPM	640 High
<b>AGITATION STROKES PER MINUTE/AMPERAGE</b>	180 SPM/High (5.0 Amps No Load) 120 SPM/Low (5.0 Amps No Load)
<b>MAXIMUM RATED CURRENT</b>	9.8 Amps (120-Volt)
<b>ELECTRICAL REQUIREMENTS</b>	120V, 60Hz., A.C. Standard 15 Amp Breaker/Fuse Branch Circuit for Each Washer
<b>SHIPPING WEIGHT (EST.)</b>	184 Lbs.
<b>DIMENSIONS</b>	
Width – in. (cm)	27 (68.5 cm)
Width – in. (cm)	25.5 (65 cm)
Height – in. (cm) at Metercase Top	43 (109 cm)
Height – in. (cm) at Lid	35 (91 cm)

Energy information is available online at [www.whirlpoolcommerciallaundry.com/products](http://www.whirlpoolcommerciallaundry.com/products)

PIN	FUNCTION
5 to neutral	Remote cycle start with remote relay closure
1 to 4	Changes state every 30 seconds
3 to 6	Cycle counter

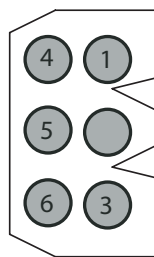

E-Z Wiring Harness Feature Connector for connection to money acceptors (located under top cover)



### 3 YEARS LIMITED PARTS ONLY WARRANTY

For a period from the date of original purchase through the time listed above, the designated parts that fail in normal commercial use will be repaired or replaced free of charge for the part itself, with the owner paying all other costs, including labor, transportation and customs duty. Chemical damage is excluded from all warranty coverage. See complete warranty for details.

Dimensions are for planning purposes only. For complete information, see installation instructions packed with product.

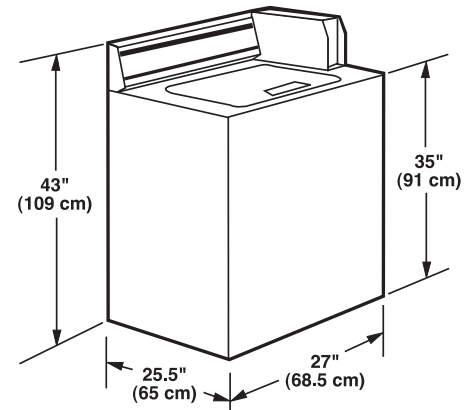

WASHER FRONT VIEW

NEW YORK CITY  
M.E.A.

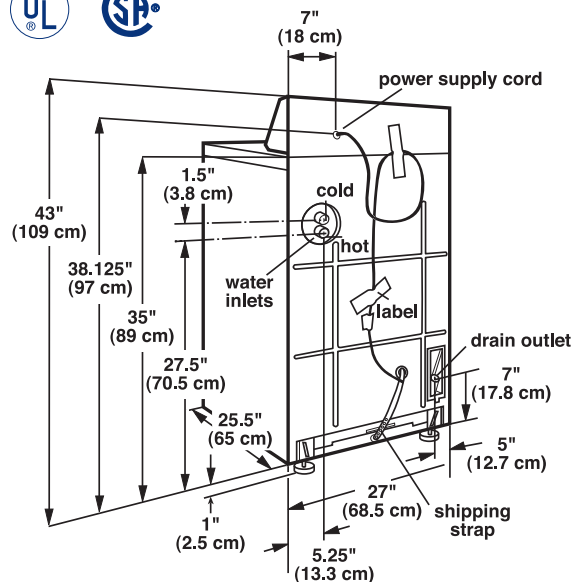

WASHER BACK VIEW

To Locate a Distributor Near You, Please Visit [www.whirlpoolcommerciallaundry.com/distributor](http://www.whirlpoolcommerciallaundry.com/distributor), or call 1-800-NO-BELTS

TORX is a registered Trademark of Textron Industries, Inc.

®Registered trademark/™Trademark of Whirlpool, U.S.A. ©2010 Whirlpool Corporation. All rights reserved.

Whirlpool Corporation • Benton Harbor, Michigan 49022 U.S.A.